

THIS DRAWING IS UNPUBLISHED. RELEASED FOR PUBLICATION 20
 © COPYRIGHT 20 BY - ALL RIGHTS RESERVED.

REVISIONS				
P	LTR	DESCRIPTION	DATE	APVD
D		REV ECO-13-020024	20DEC2013	GG RA

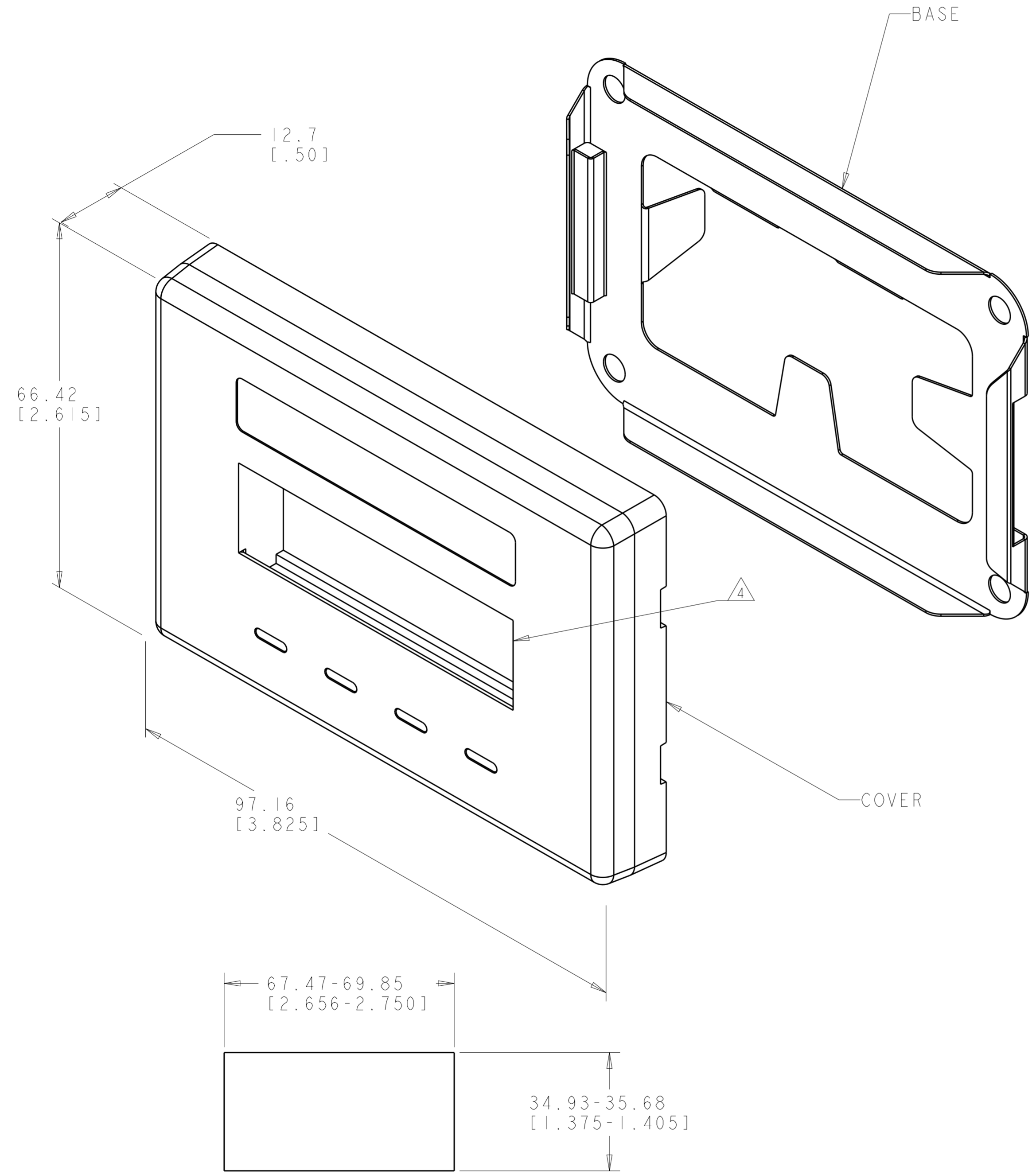

- 1. MATERIAL: COVER - ABS MOLDING COMPOUND, SEE TABLE FOR COLOR.
BASE - GALVANIZED CARBON STEEL.
- 2. KIT SHIPPED UNASSEMBLED.
- 3. DIMENSIONS SHOWN ARE NOMINAL UNLESS OTHERWISE SPECIFIED.
- 4. COVER WILL ACCEPT A COMBINATION OF FOUR SL TOOLLESS JACKS, MT-RJ FIBER OPTIC JACKS OR MULTIMEDIA INSERTS.
- 5. REFER TO INSTRUCTION SHEET 408-8397 FOR INSTALLATION PROCEDURES.

ALPINE WHITE	I-1375005-3
NEMA GRAY	1375005-4
WHITE	1375005-3
BLACK	1375005-2
LT ALMOND	1375005-1
COLOR	PART NUMBER

SUGGESTED PANEL CUTOUT

THIS DRAWING IS A CONTROLLED DOCUMENT.		DWN L HALL 23AUG2000	TE Connectivity		
DIMENSIONS: mm [INCHES]		CHK G BOWMAN 23AUG2000			
TOLERANCES UNLESS OTHERWISE SPECIFIED:		APVD G BOWMAN 23AUG2000			
0 PLC ±	1 PLC ±	PRODUCT SPEC	NAME ASSEMBLY, FURNITURE OUTLET SMALL BASE		
2 PLC ±	3 PLC ±	APPLICATION SPEC	SIZE A2		
4 PLC ±	ANGLES ±	408-8397	CAGE CODE - DRAWING NO C-1375005		
FINISH		WEIGHT -	RESTRICTED TO -		
MATERIAL		Customer Drawing	SCALE 2:1	SHEET 1 OF 1	REV D